

Instructions for use

LGO-Side Fire Fiber Group

1. LGO-Side Fire Fiber

The group of LGO-Side Fire Fiber covers medical grade optical fiber probes for application in various fields of laser surgery, as described in section 1.2 about the intended use. These are sterile packed single-use devices for transmission of laser radiation which is emitted laterally at the probe's end. For this purpose the probe's end is equipped with a cap made from quartz glass. The group of LGO-Side Fire Fibers is composed of the following product variations:

Variation	Light emission profile	Tip Shape	Core diameter
LGO-Saturn Side Fiber	circular 360° annular, under 60° to the axis	diameter 1.6 mm to 2.3 mm (depending on style), rounded	min. 545 µm
LGO-Saturn Slight Side Fiber	circular 360° annular, under 60° to the axis	diameter 1.0 mm to 1.3 mm (depending on style), rounded	400 µm
LGO-Side Fire Fiber Probe	one-sided, point-shaped, under 80° to the axis	diameter 1.8 mm, rounded	min. 545 µm
LGO-Fistula Probe	circular 360° annular, under 60° to the axis	diameter 1.8 mm, rounded	min. 545 µm
LGO-Hemorrhoid Probe	cone which points forwards, circular 360°	diameter 1.8 mm, rounded	min. 545 µm
LGO-Infinity Side Fiber	cylindrical 360° all around, approx. 4 mm long	diameter 1.6 mm to 1.8 mm (depending on style), rounded	min. 545 µm

The members of the LGO-Side Fire Fiber Group can be operated with laser consoles of different wavelengths in the range from 700 nm to 2000 nm. Prior to the treatment the compatibility must be checked. If a laser manufacturer offers the LGO-Side Fire Fiber product as a genuine accessory product, the compatibility test with that laser device has already been performed and does not need to be performed again.

1.1. Compatibility check

The following technical data of the optical fiber probe and the laser console must be checked for agreement prior to commencing the treatment:

- a) The laser device in use must have a beam diameter at least 5% smaller than the core diameter of the optical fiber. The core diameter of the optical fiber can be taken from the table above. It can also be deduced from the item description (label) in the unit of micrometers.
- b) The numerical aperture (NA) of the laser device in use must not exceed 0.22, except for cases in which a higher value is stated explicitly in the product label.

In the case of doubt, contact your technical service or supplier and dispense with the use until the problem has been solved fully.

1.2. Intended use and exclusions

The intended use of the optical fiber probes in the LGO-Side Fire Fiber group is to deliver laser radiation from its source to the treatment site of the patient in the context of a medical laser surgery. The optical fiber probes are indicated in laser surgery application of different disciplines in minimally invasive surgery. Follow the current clinical specialist guidelines, in particular for the selection of the source of laser radiation and laser power. Any off-label use of the LGO-Side Fire Fiber product is fully under the user's responsibility. By all means the technical fiber compatibility aspects (section 1.1) must be respected.

Applications at the central nervous system and the central circulatory system are not allowed. Additionally, surgeries in the vicinity of brackets or implants are not allowed because there is the risk of heating and destruction. In order to ensure correct and safe handling this device may only be applied by physicians being familiar with the handling of medical laser devices, and with the therapeutic application of medical laser consoles.

1.3. Potential risks associated with the application

Please refer to the instructions for use of the medical laser device and the corresponding specialist medical literature for a full outline of possible side effects. Possible side effects depend on the medical discipline in which this device is used in. Side effects can be but are not limited to: bruising / ecchymosis / hematoma, paresthesia, thrombosis, pulmonary embolism, induration, burn / necrosis, formation of edema, phlebitis, bleeding, itching, perianal thrombosis, urinary retention, abscess formation, major forms of incontinence, or anismus.

2. Application guidelines and safety rules

Prior to the start of the laser treatment, all necessary instructions for use of the equipment employed must be read and fully understood. In the case of doubt, please contact your technical service or supplier and dispense with the use until the doubts have been dispelled.

2.1. Application guidelines and safety rules

Depending on the specific application it is indicated to use the probe from the LGO-Side Fire Fiber group in conjunction with an introducer sheath, a cannula, a handpiece, or an endoscopic instrument to safely position the tip of the optical fiber probe, hence the laser beam. Details for safe positioning of the optical fiber tip are provided in chapter 3. In cases when the tip of the optical fiber probe is not visible, it is necessary to localize it by means of the aiming beam through the skin. Make use of imaging techniques such as ultrasound for applications in soft tissue without endoscope to ensure correct positioning and alignment towards the target tissue. Depending on the indication, a continuous irrigation and clear view of the tissue to be treated is only maintained with an endoscopic instrument. The products of the LGO-Side Fire Fiber group may not be operated exposed to air.

Typical treatment parameters and laser settings depend on the individual case. Please consult the specialist medical literature. For direct tissue contact, typical maximum powers are 10 W to 15 W, depending on the laser wavelength used and the associated laser-tissue interaction. Under continuous irrigation by water, the maximum power is 100 W.

Always start with low power and adjust the laser settings depending on the course of the treatment while observing the effects on the tissue. Overheating of the quartz glass cap at the tip of the optical fiber is to be prevented. To do so the laser power has to be selected appropriately. When the laser is active, the optical fiber tip should always be kept in steady motion in the target tissue or surrounded by irrigation fluid completely.

Tissue adhesion reduces the amount of laser power which is available for the treatment and causes the probe to heat up, leading to wear of the quartz glass cap. Adhesion of tissue should be removed after some seconds of cool down time by carefully rubbing at tissue or at a sterile moist swab. Laser pyrolysis products (gas, steam,

particles, infection aerosols, ...), which are created during the treatment, should be removed using a suction system above the treatment area.

The laser treatment should be limited to a period of time that is strictly necessary for the therapeutic effect. Information on patient care and follow-up resulting from literature must be observed in order to avert or minimize unwanted side effects of laser treatment.

2.2. Safety regulation

Increased care is required when handling fiber optic probes. These fiber optic probes are damaged by bending, kinking, tensile loads, shocks or twists. During the treatment they must never be bent with a radius smaller than this:

Variation	Minimum bend radius
LGO-Saturn Slight Side Fiber	21 mm
All others	35 mm

When selecting an introducer sheath, cannula, handpiece, or endoscopic instrument, the diameter of its working channel must be chosen such that the optical fiber probe can be smoothly inserted into the working channel.

Throughout the entire course of the treatment make sure that the quartz glass cap of the optical fiber always protrudes from the instrument completely, see chapter 3. Optical fiber and instrument can be destroyed if the laser radiation is emitted in the instrument.

The general instructions and information with regard to a safe handling with laser radiation have to be applied (including eye protection). Safety relevant information has to be extracted from the labelling of the laser devices and their reference manuals.

The use of medical devices may result in biological risk. Medical devices have to be used and disposed of in accordance with legal regulations and accepted practice.

Pay special attention to the cleanliness of the connector and the integrity of the distal end. The product must not be used if the connector or the quartz glass cap fixed to the distal end is damaged or broken.

After connection to the laser device the aiming beam must be visible as laterally emitted light. The specific light emission pattern (see page 1) must be visible. If this is not the case, the product shall not be used.

After the treatment the optical fiber probe must be inspected for damage particularly at the distal quartz cap. In the unlikely event of the fiber tip breaking off and remaining in the body (or if this is considered possible) respective clinical measures are to be taken.

2.3. Symbol explanation



The product must be kept in a dry place and at the given temperature range.



Prior to use check the packaging for damage. Do not use if the packaging is damaged.



The product has been sterilized with ethylene oxide (EO).



Do not reuse. This product is intended for use with a single patient during a single treatment. Sterility and function cannot be guaranteed for reuse.



Mind the instructions. It is necessary for the user to consult the instructions for use prior to use.



Expiration date: Indicates the date after which the medical device must not be used.



Manufacturer: Symbol indicates the manufacturer of the medical device according to the guidelines 90/385/EEC, 93/42/EEC and 98/79/EC.



Batch code: Indicates the batch number of the manufacturer so that the batch can be identified.

3. Application of the LGO-Side Fire Fiber products with the LGO-Introducer Set or other cannulas and instruments

During application of the LGO-Side Fire Fiber products with the LGO-Introducer Set, cannulas and instruments the user has to ensure that the quartz glass cap of the optical fiber (distal end) fits through the working channel smoothly and always protrudes completely during the treatment.

For the product variation LGO-Infinity Side Fiber and LGO-Saturn Side Fiber with 1.8 mm diameter of the quartz glass cap a suitable introducer set is available, the LGO-Introducer Set 6F. In this combination, a marker (arrows or bars) will appear on the proximal side of the catheter, leaving about 20 mm of space:

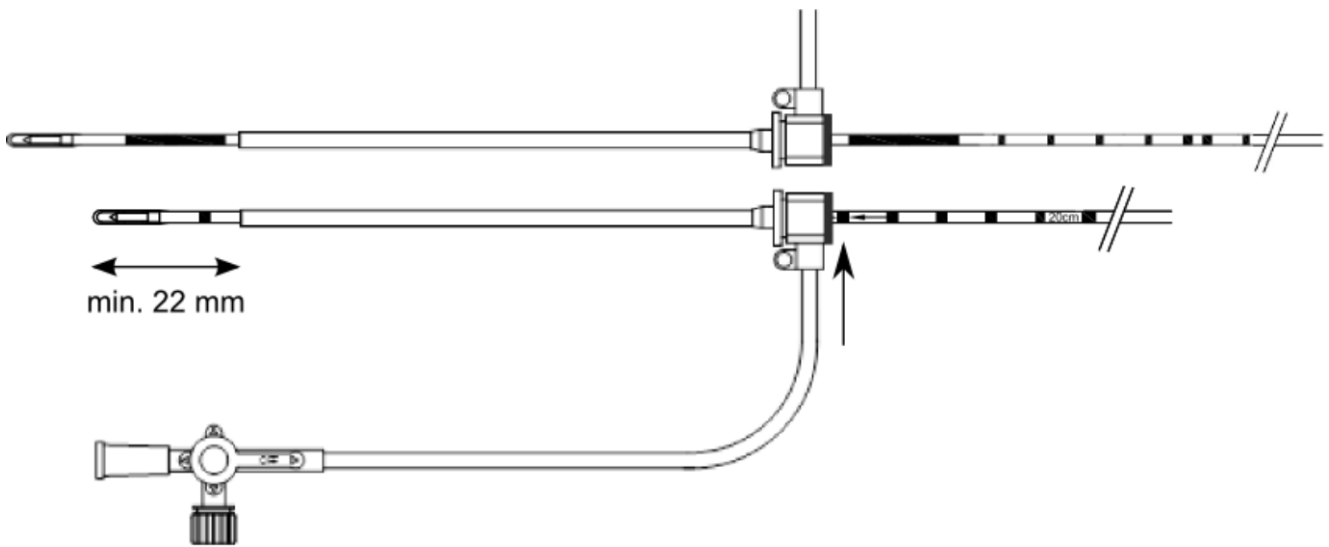

For the use of the LGO-Saturn Slight Side Fiber and LGO-Fistula Probe in cannulas, marking lines are applied at intervals of 5 mm and 10 mm. Prior to treatment make yourself familiar with your selected cannula.

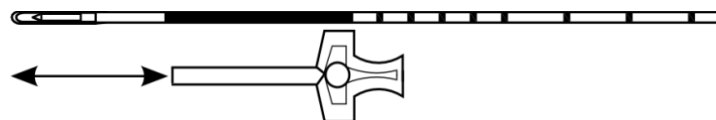

LGO-Hemorrhoid Probe and LGO-Side Fire Fiber Probe have got squeeze adapters and / or stoppers which can be used for fixing them to a handpiece or an endoscopic instrument. Prior to the treatment make yourself familiar with the instrument of your choice and the position of the optical fiber probe inside of it.

4. Disclaimer

Light Guide Optics International Ltd does not accept any liability for personal injuries as well as for damages of the laser device due to an inappropriate handling and storage of the LGO-Side Fire Fiber.

Light Guide Optics International Ltd cannot be held responsible for indirect damages or consequential damages, losses and expenses with respect to a direct or indirect application of these products.

Light Guide Optics International Ltd does not accept any responsibility neither in terms of the application of the LGO-Side Fire Fiber nor in terms of possible side effects of the medical laser treatment with this laser fiber probe.



Light Guide Optics International Ltd.
Celtniecibas Street 8
LV-5316 Livani
Latvia

Light Guide Optics Sales and Customer Service:
LightGuideOptics Germany GmbH
Tel. +49 2225 70953 0
Fax +49 2225 70953 20
E-Mail info@lgoptics.de
Release of this version on: 2020-06-29